

Overview

tailBeacon is a 2020 compliant, near zero-install, Class B1S ADS-B UAT transmitter and WAAS GPS integrated into a rear position light. The power transcoder decodes replies from legacy Mode C and Mode S transponders. 14 CFR §91.227 compliant. Smart phone configurable over Wi-Fi.

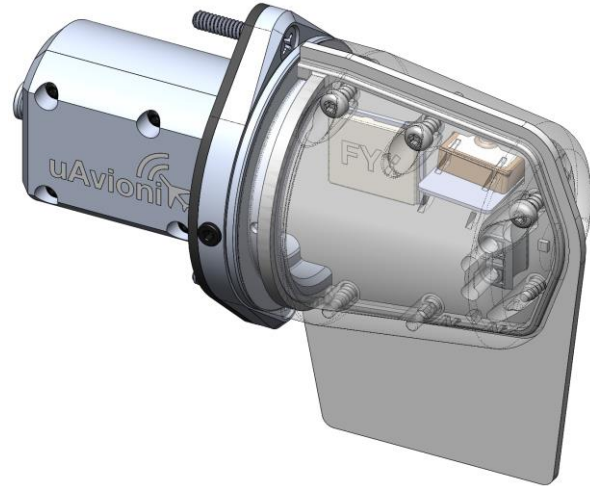

Features

UAT Transmitter

- Meets the performance requirements of TSO-154c (RTCA/DO-282B) Class B1S

Position Light

- Meets performance requirements of TSO-C30c Type III

WAAS GPS

- Meets the performance requirements of TSO-C145e (RTCA/DO-229E) Class Beta 1
- Integrated RAIM processor for Security and Integrity protection
- SBAS corrections and health messages used to detect and correct satellite range errors
- Satellite pseudo range step errors detected and excluded
- SBAS fast and long-term corrections applied

Power Transcoder

- Decodes altitude and squawk via aircraft electrical system

Certification

- Pending TSO certification for installation by Approved Model List (AML) STC on hundreds of aircraft makes and models

Patents Pending

Regulatory

- FCC ID 2AFFTUAT016R
- ADS-B Out: §91.225, §91.227, AC 20-165B
- GNSS Position: AC 20-165B
- Position Light: SAE/AS8037

Technical Specifications

Specification	Value
Input Voltage	11-31V DC
Operating Power	3watts
Size	92x43x73mm
Weight	70grams
SDA/SIL	2/3
Operating Temp	-45 to 70°C
978MHz UAT Transmitter	
Power Classification	DO-282B Medium Power
WAAS GPS	
Tracking	-166dBm
Reacquisition	-160dBm
Cold Start	-148dBm
LED Position Light	
Color	Aviation White
Intensity	40 candelas
Wi-Fi Configuration	
Physical	802.11b/g/n
App Compatibility	iOS, Android
Power Transcoder	
Decodes Mode A,C and S via DC input	

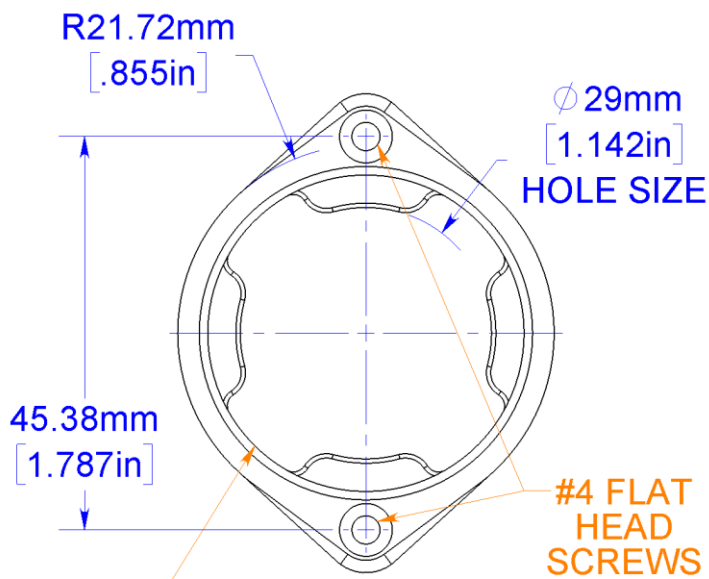
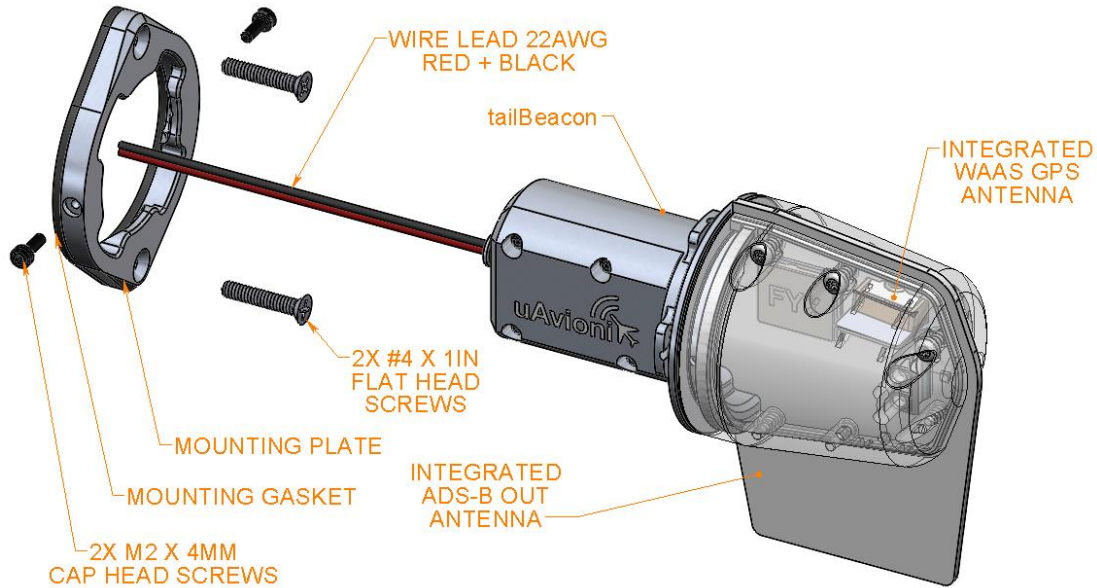

MOUNTING RING CAN BE INSTALLED WITH SCREWS HORIZONTAL OR VERTICAL

uAvionix products are warranted to be free from defects in material and workmanship for one year from the date of installation in the aircraft. For the duration of the warranty period, uAvionix, at its sole option, will repair or replace any product which fails in normal use. Such repairs or replacement will be made at no charge to the customer for parts or labor, provided that the customer shall be responsible for any transportation cost.